

- I** Bruciatori di gasolio
- GB** Gas oil burners
- F** Brûleurs fioul domestique
- D** Öl-Gebläsebrenner
- E** Quemadores de gasóleo

Funzionamento bistadio progressivo o modulante
Progressive two-stage or modulating operation
Fonctionnement à 2 allures progressives ou modulant
Gleitend-zweistufiger oder modulierender Betrieb
Funcionamiento con dos llama progresivo o modulante

CODICE - CODE CÓDIGO	MODELLO - MODEL - MODELE MODELL - MODELO	TIPO - TYPE - TYP
20032806	RL 70/M	669 T1
20034204	RL 70/M	669 T1
20032813	RL 100/M	670 T1
20034206	RL 100/M	670 T1
20032818	RL 130/M	671 T1
20034272	RL 130/M	671 T1

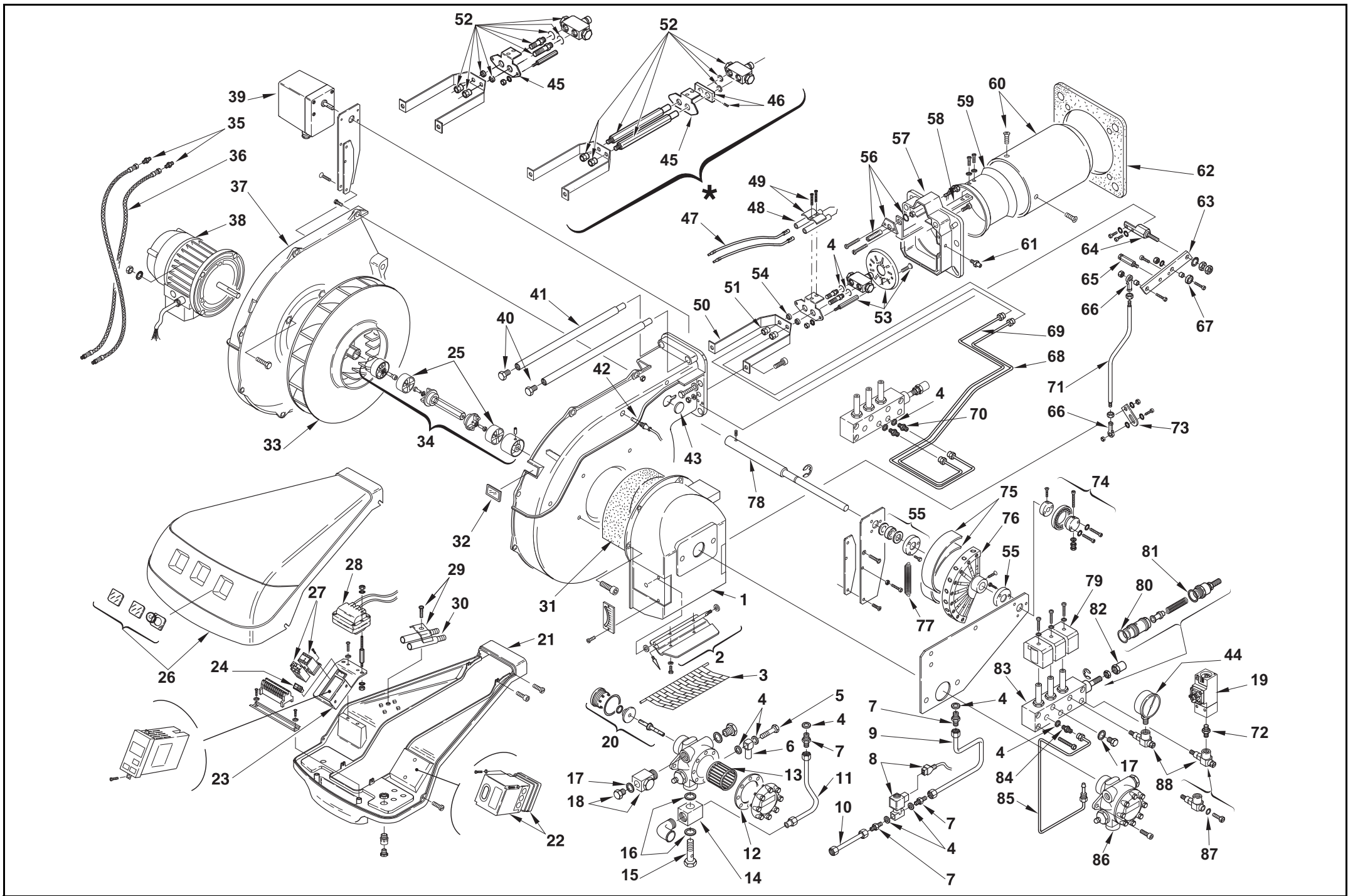

N.	COD.	20032806	20034204 *	20032813	20034206 *	20032818	20034272 *	DESCRIZIONE	DESCRIPTION	DESCRIPTION	BESCHREIBUNG	DENOMINACION	MATRICOLA BRUCIATORE BURNER SERIAL NUMBER MATRICULE BRULEUR BRENNER KENN-NUMMER MATRICULA QUEMADORES	**
1	3012454	•	•	•	•	•	•	BOCCA D'ASPIRAZIONE	AIR INTAKE	BOITIER D'ASPIRATION	ANSAUGÖFFNUNG	BOCA ASPIRACION		
2	3003948	•	•	•	•	•	•	GRUPPO SERRANDA	AIR DAMPER ASSEMBLY	GROUPE VOLET AIR	LUFTKLAPPE	REGISTRO AIRE		
3	3003949	•	•	•	•	•	•	PROTEZIONE	GRID	PROTECTION	SCHUTZGITTER	PROTECCIÓN		
4	3007079	•	•	•	•	•	•	GUARNIZIONE	SEAL	RONDELLE	METALLDICHTUNG	JUNTA		A
5	3003006	•	•	•	•	•	•	RACCORDO	CONNECTOR	MAMELON	NIPPEL	RACORD		C
6	3012455	•	•	•	•	•	•	RACCORDO	CONNECTOR	MAMELON	NIPPEL	RACORD		C
7	3009081	•	•	•	•	•	•	RACCORDO	CONNECTOR	MAMELON	NIPPEL	RACORD		C
8	3006373			•	•	•	•	VALVOLA	SOLENOID VALVE	ELECTRO-VANNE	MAGNET VENTIL	VÁLVULA		B
9	3012456			•	•	•	•	TUBO	TUBE	TUYAUTERIE	DRUCKROHR	TUBO		
10	3012457			•	•	•	•	TUBO	TUBE	TUYAUTERIE	DRUCKROHR	TUBO		
11	3012458	•	•	•	•			TUBO	TUBE	TUYAUTERIE	DRUCKROHR	TUBO		
12	20034170	•	•	•	•	•	•	GUARNIZIONE	SEAL	JOINT COUVERCLE POMPE	PUMPENDICHTUNG	JUNTA		A
13	3006787	•	•	•	•	•	•	FILTRO	FILTER	FILTRE	PUMPENFILTER	FILTRO		A
14	3003055	•	•	•	•	•	•	RACCORDO	CONNECTOR	MAMELON	NIPPEL	RACORD		C
15	3006184	•	•	•	•	•	•	PERNO	SCREW	VIS CREUSE	HOHLKERNSCHRAUBE	PERNO		C
16	3007164	•	•	•	•	•	•	GUARNIZIONE	SEAL	RONDELLE	METALLDICHTUNG	JUNTA		A
17	3007077	•	•	•	•	•	•	GUARNIZIONE	SEAL	RONDELLE	METALLDICHTUNG	JUNTA		A
18	3003681	•	•	•	•	•	•	RACCORDO	CONNECTOR	MAMELON	NIPPEL	RACORD		C
19	3014180R	•	•	•	•	•	•	PRESSOSTATO OLIO	OIL PRESSURE SWITCH	PRESSOSTAT FIOUL	PRESSOSTAT	PRESÓST. DE GASÓLEO		B
20	3000805	•	•	•	•	•	•	ORGANO DI TENUTA	PUMP SEAL	ORGANE D'ETANCHEITE	WELLENDICHTUNG	CONJUNTO ESTANQUIDAD		A
21	3012459	•	•	•	•	•	•	MENSOLA	BASE PLATE	PLAQUE DE SUPPORT	GRUNDPLATTE	SOPORTE		
22	3006215	•	•	•	•	•	•	APPARECCHIATURA	CONTROL BOX	BOITE DE CONTROLE	STEUERGERÄT	CAJA CONTROL		B
23	3012343	•	•	•	•	•	•	SUPPORTO	SUPPORT	SUPPORT	HALTER	SOPORTE		
24	3012080	•	•	•	•	•	•	INTERRUTTORE	SWITCH	INTERRUPTEUR	SCHALTER	INTERRUPTOR		C
25	3012622	•	•	•	•	•	•	DISCO ELASTICO	DRIVE DISK	DISQUE ELASTIQUE	KUPPLUNGSSCHEIBE	DISCO ELASTICO		
26	3013119	•	•	•	•	•	•	COFANO	COVER	COFFRET	VERKLEIDUNG	ENVOLVENTE		
27	3003959	•	•					AVVIATORE	STARTER	DEMARREUR	ANLASSER	ARRANCADOR		C
27	3003960			•	•			AVVIATORE	STARTER	DEMARREUR	ANLASSER	ARRANCADOR		C
27	3003961					•	•	AVVIATORE	STARTER	DEMARREUR	ANLASSER	ARRANCADOR		C
28	3003785	•	•	•	•	•	•	TRASFORMATORE	TRANSFORMER	TRANSFORMATEUR	ZÜNDTRANSFORMATOR	TRANSFORMADOR		B
29	3003409		•		•			CAVALLOTTO	U BOLT	CAVALIER	BÜGELBOLZEN	FIJACION ELECTRODO		
30	3003956		•		•			PROLUNGA PERNO	BAR EXTENSION	RALLONGE DE GLISSIERE	VERLÄNGERUNG	PROLUNGACION GUIA		C
31	3003952	•	•	•	•	•	•	FONOASSORBENTE	SOUND DAMPING	INSONORISANT	GERÄUSCHDÄMMUNG	AISLAMIENTO ACÚSTICO		

N.	COD.	20032806	20034204 *	20032813	20034206 *	20032818	20034272 *	DESCRIZIONE	DESCRIPTION	DESCRIPTION	BESCHREIBUNG	DENOMINACION	MATRICOLA BRUCIATORE	**
													BURNER SERIAL NUMBER	
32	3003763	•	•	•	•	•	•	VISORE	INSPECTION WINDOW	WISEUR	SICHTFENSTER	VISOR		
33	3003955	•	•					GIRANTE	FAN	TURBINE	GEBLÄSERAD	TURBINA		C
33	3003964			•	•			GIRANTE	FAN	TURBINE	GEBLÄSERAD	TURBINA		C
33	3003965					•	•	GIRANTE	FAN	TURBINE	GEBLÄSERAD	TURBINA		C
34	3003954	•	•	•	•	•	•	GRUPPO GIUNZIONE	DRIVE COUPLING	ACCOUPEMENT	KUPPLUNG	CONJUNTO		A
35	3009068	•	•	•	•	•	•	RACCORDO	CONNECTOR	MAMELON	NIPPEL	RACORD		C
36	20034084	•	•	•	•	•	•	TUBO FLESSIBILE	FLEXIBLE OIL LINE	FLEXIBLE	SCHLAUCH	TUBO FLEXIBLE		A
37	3012012	•	•	•	•	•	•	GUSCIO	HALF-SHELL	COUVERCLE	HAUBE	CASCARA		
38	3003966	•	•					MOTORE	MOTOR	MOTEUR	MOTOR	MOTOR		C
38	3013367			•	•			MOTORE	MOTOR	MOTEUR	MOTOR	MOTOR		C
38	3003968					•	•	MOTORE	MOTOR	MOTEUR	MOTOR	MOTOR		C
39	3012345	•	•	•	•	•	•	SERVOMOTORE	SERVOMOTOR	SERVOMOTEUR	STELLMOTOR	SERVOMOTOR		B
40	3003481	•	•	•	•	•	•	VITE	SCREW	VIS	SCHRAUBE	TORNILLO		
41	3003970	•	•	•	•	•	•	PERNO	BAR	GLISSIERE	BOLZEN	GUIA		C
42	3012091	•	•	•	•	•	•	FOTOCELLULA	U.V. DETECTOR	PHOTOCELLULE U.V.	U.V. PHOTOZELLE	FOTOCELULA U.V.		A
43	3003996	•	•	•	•	•	•	TAPPO	PLUG	BOUCHON A VIS	SCHRAUBSTÖPSEL	TAPON		
44	3006140	•	•	•	•	•	•	MANOMETRO	PRESSURE GAUGE	MANOMETRE	MANOMETER	MANOMETRO		A
45	3012092	•		•	•			SUPPORTO	SUPPORT	SUPPORT	HALTER	SOPORTE		
45	3012128		•		•	•		SUPPORTO	SUPPORT	SUPPORT	HALTER	SOPORTE		
46	3003790		•		•	•		PIASTRA	ANCHOR PLATE	PLATINE DE BLOCAGE	ARRETIERPLATTE	PLATINA		
47	3012393	•		•		•		COLLEGAMENTO	H.T. LEAD	CABLE H.T.	ZÜNDKABEL	CABLES ELECTRODOS		A
47	3003973		•		•	•		COLLEGAMENTO	H.T. LEAD	CABLE H.T.	ZÜNDKABEL	CABLES ELECTRODOS		A
48	3003796	•	•	•	•	•	•	ELETTRODO	ELECTRODE	ELECTRODE PORCELAINE	ELEKTRODE	ELCTRODO		A
49	3003495	•	•	•	•	•	•	CAVALLOTTO	U BOLT	CAVALIER	BÜGELBOLZEN	FIJACION ELECTRODO		
50	3012461	•	•	•	•	•	•	SUPPORTO	SUPPORT	SUPPORT	HALTER	SOPORTE		
51	3012095	•	•	•	•	•	•	DADO	NUT	ECROU BORGNE	MUTTER	TUERCA		
52	3012096	•	•	•	•	•	•	GRUPPO PORTAUGELLO	NOZZLE HOLDER	GROUPE PORTE-GICLEUR	DÜSENSTOCK	GRUPO PORTABOQUILLA		C
53	3012462	•	•					ELICA	DIFFUSER DISC	ACCROCHE FLAMME	STAUSCHEIBE	DISCO ESTALIBIZADOR		A
53	3012463			•	•	•	•	ELICA	DIFFUSER DISC	ACCROCHE FLAMME	STAUSCHEIBE	DISCO ESTALIBIZADOR		A
54	3012127	•		•	•	•		DISTANZIALE	SPACER	ENTRETOISE	DISTANZSTÜCK	DISTANCIADOR		
55	3012357	•	•	•	•	•	•	CUSCINETTO	BEARING	ROULEMENT	LAGER	COJINETE		
56	3003974	•	•	•	•	•	•	GRUPPO REGOLATORE	CONTROL DEVICE	GROUPE OBTURATION	DRUCKREGULIERUNG	CONJUNTO REGULACION		
57	3003975	•	•	•	•			FRONTONE	FONT PIECE	FACADE	VORDERTEIL	TUBO LLAMA		

N.	COD.	20032806	20034204 *	20032813	20034206 *	20032818	20034272 *	DESCRIZIONE	DESCRIPTION	DESCRIPTION	BESCHREIBUNG	DENOMINACION	MATRICOLA BRUCIATORE BURNER SERIAL NUMBER MATRICULE BRULEUR BRENNER KENN-NUMMER MATRICULA QUEMADÓRES	* *
57	3003976					•	•	FRONTONE	FONT PIECE	FACADE	VORDERTEIL	TUBO LLAMA		
58	3012464	•						SQUADRETTA	SQUARE	EQUERRE-SUPPORT	HALTER	ESCUADRA		
58	3003978		•					SQUADRETTA	SQUARE	EQUERRE-SUPPORT	HALTER	ESCUADRA		
58	3012465			•				SQUADRETTA	SQUARE	EQUERRE-SUPPORT	HALTER	ESCUADRA		
58	3003980				•			SQUADRETTA	SQUARE	EQUERRE-SUPPORT	HALTER	ESCUADRA		
58	3012466					•		SQUADRETTA	SQUARE	EQUERRE-SUPPORT	HALTER	ESCUADRA		
58	3003982					•		SQUADRETTA	SQUARE	EQUERRE-SUPPORT	HALTER	ESCUADRA		
59	3003983	•	•	•	•			OTTURATORE	SHUTTER	OBTURATEUR	SCHIEBER	OBTURADOR		C
59	3003984					•	•	OTTURATORE	SHUTTER	OBTURATEUR	SCHIEBER	OBTURADOR		C
60	3012467	•						IMBUTO FIAMMA	END CONE	EMBOUT GUEULARD	FLAMMENROHR	TUBO LLAMA		B
60	3003986		•					IMBUTO FIAMMA	END CONE	EMBOUT GUEULARD	FLAMMENROHR	TUBO LLAMA		B
60	3012468			•				IMBUTO FIAMMA	END CONE	EMBOUT GUEULARD	FLAMMENROHR	TUBO LLAMA		B
60	3003988				•			IMBUTO FIAMMA	END CONE	EMBOUT GUEULARD	FLAMMENROHR	TUBO LLAMA		B
60	3012469					•		IMBUTO FIAMMA	END CONE	EMBOUT GUEULARD	FLAMMENROHR	TUBO LLAMA		B
60	3003990					•		IMBUTO FIAMMA	END CONE	EMBOUT GUEULARD	FLAMMENROHR	TUBO LLAMA		B
61	3003322	•	•	•	•	•	•	RACCORDO	CONNECTOR	MAMELON	NIPPEL	RACORD		C
62	3003991	•	•	•	•	•	•	SCHERMO	FLANGE GASKET	ECRAN THERMIQUE	FLANSCHDICHTUNG	JUNTA AISLANTA		A
63	3012354	•	•	•	•	•	•	LEVA	LEVER	LEVIER	HEBEL	PALANCAS		
64	3012353	•	•	•	•	•	•	PERNO	SCREW	VIS CREUSE	HOHLKERNSCHRAUBE	GUIA		C
65	3012352	•	•	•	•	•	•	PERNO	SCREW	VIS CREUSE	HOHLKERNSCHRAUBE	GUIA		C
66	3006098	•	•	•	•	•	•	SNODO SFERICO	PIN JOINT	CHAPE A ROTULE	KUGELGELENK	ARTICOLACION ENSFER.		
67	3003841	•	•	•	•	•	•	CUSCINETTO	BEARING	ROULEMENT	LAGER	CONJINETE		
68	3012470	•	•	•	•	•	•	TUBO	TUBE	TUYAUTERIE	DRUCKROHR	TUBO		
69	3012471	•	•	•	•	•	•	TUBO	TUBE	TUYAUTERIE	DRUCKROHR	TUBO		
70	3003005	•	•	•	•	•	•	RACCORDO	CONNECTOR	MAMELON	NIPPEL	RACORD		C
71	3012351	•	•	•	•	•	•	TIRANTE	TIE ROD	TIRANT	GESTÄNGE	TIRANTE		
72	3009080	•	•	•	•	•	•	RACCORDO	CONNECTOR	MAMELON	NIPPEL	RACORD		C
73	3012359	•	•	•	•	•	•	LEVA	LEVER	LEVIER	HEBEL	PALANCA		
74	3012472	•	•	•	•	•	•	CUSCINETTO	BEARING	ROULEMENT	LAGER	COJINETE		
75	3006097	•	•	•	•	•	•	MOLLA	FLAT SPRING	RESSORT PLAT	KURVENBAND	MUELLE		A
76	3012358	•	•	•	•	•	•	CAMMA COMPLETA	CAM ASSEMBLY	CAME COMPLETE	VERBUNDREGLER	EXENTRICO COMPLETO		C
77	3012356	•	•	•	•	•	•	MOLLA	SPRING	RESSORT	FEDER	MUELLE		A
78	3012473	•	•	•	•	•	•	ALBERO	SHAFT	ARBRE	WELLE	ARBOLILLO		

N.	COD.	20032806	20034204 *	20032813	20034206 *	20032818	20034272 *	DESCRIZIONE	DESCRIPTION	DESCRIPTION	BESCHREIBUNG	DENOMINACION	MATRICOLA BRUCIATORE BURNER SERIAL NUMBER MATRICULE BRULEUR BRENNER KENN-NUMMER MATRICULA QUEMADORES	* *
		•	•	•	•	•	•							
79	3003001	•	•	•	•	•	•	BOBINA	COIL	BOBINE E.V.	MV-SPULE	BOBINA		B
80	3007150	•	•	•	•	•	•	ANELLO OR	O RING	JOINT TORIQUE	O RING	JUNTA TORICA		B
81	3003204	•	•	•	•	•	•	GUARNIZIONE	SEAL	RONDELLE	METALLDICHTUNG	JUNTA		A
82	3003200	•	•	•	•	•	•	DADO	NUT	ECROU BORGNE	MUTTER	TUERCA		
83	3012474	•	•	•	•	•	•	MODULATORE	MODULATOR	MODULATEUR	MODULATOR	MODULADOR		B
84	3006723	•	•	•	•	•	•	RACCORDO	CONNECTOR	MAMELON	NIPPEL	RACORD		C
85	3012475	•	•	•	•	•	•	TUBO	TUBE	TUYAUTERIE	DRUCKROHR	TUBO		
86	20031716	•	•	•	•	•	•	POMPA	PUMP	POMPE	PUMPE	BOMBA		C
87	3007169	•	•	•	•	•	•	ANELLO OR	O RING	JOINT TORIQUE	O RING	JUNTA TORICA		B
88	3012476	•	•	•	•	•	•	VALVOLA DI SCARICO	NEEDLE VALVE	ROBINET POINTEAU	NADELVENTIL	VALVULA DE ESCAPE		

*

Versione Testa Lunga - Long Combustion Head Version - Version Tête Longue - Langer Brennkopf Ausführung - Versión alargado de tubo llama

**

RICAMBI CONSIGLIATI - ADVISED PARTS - RECHANGE CONSEIL - EMPFOHLENE ERSATZTEILE - RECAMBIOS ACONSEJADOS

A = Ricambi per dotazione minima - Spare parts for minimum fittings - Pièces détachées pour équipement minimum - Ersatzteile für minimale Ausstattung - Recambios para equipamiento mínimo

A+B = Ricambi per dotazione base di sicurezza - Spare parts for basic safety fittings - Pièces détachées pour équipement standard de sécurité - Ersatzteile für Sicherheitsgrundausrüstung - Recambios para equipamiento básico de seguridad

A+B+C = Ricambi per dotazione estesa di sicurezza - Spare parts for extended safety fittings - Pièces détachées pour équipement complet de sécurité - Ersatzteile für erweiterte Sicherheitsausstattung - Recambios para equipamiento general de seguridad

The logo for RIELLO, consisting of the word "RIELLO" in a bold, red, sans-serif font.

RIELLO S.p.A.
I-37045 Legnago (VR)
Tel.: +39.0442.630111
[http:// www.riello.it](http://www.riello.it)
[http:// www.rielloburners.com](http://www.rielloburners.com)